

MASON-MERCER

STAINLESS STEEL & BRONZE BRAIDED VEE

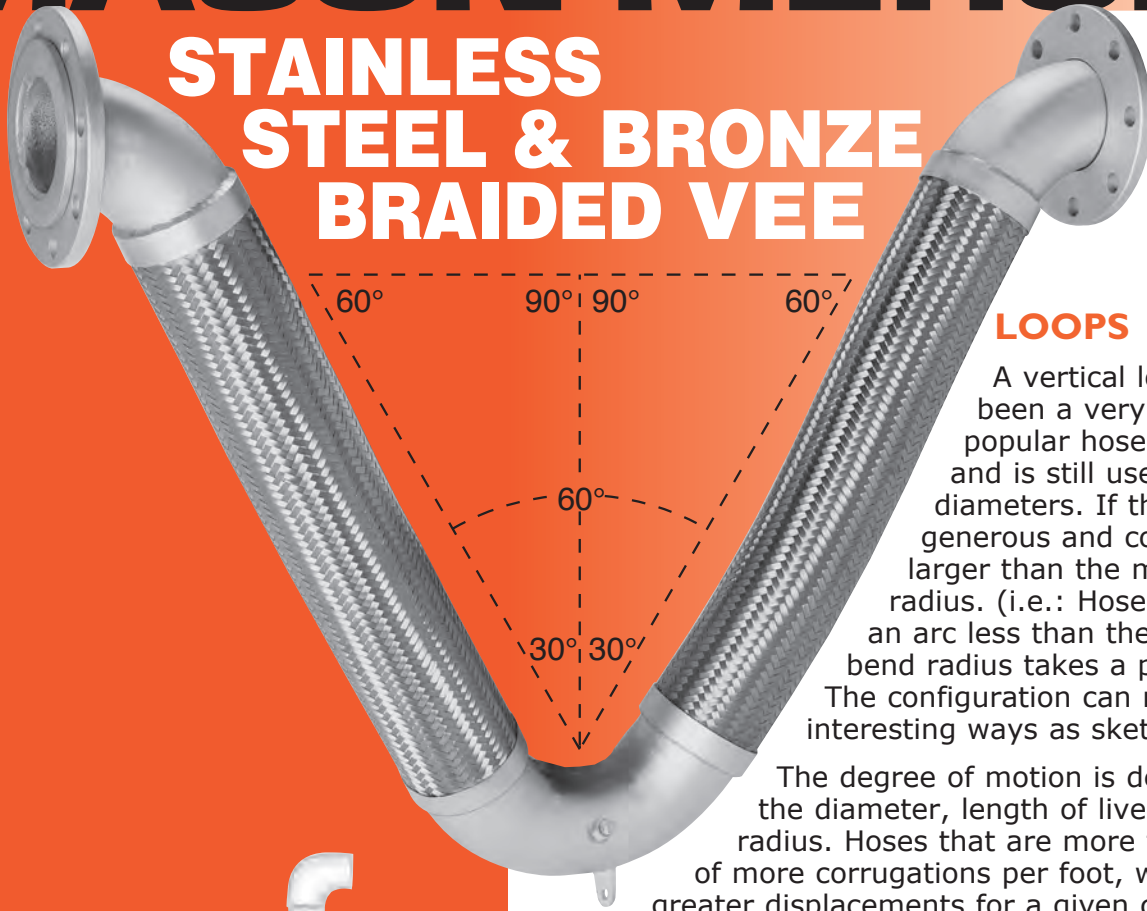

LOOPS

A vertical loop has always been a very useful and popular hose configuration and is still used in small diameters. If the radius is generous and considerably larger than the minimum bend radius. (i.e.: Hose forced into an arc less than the minimum bend radius takes a permanent set.) The configuration can move in many interesting ways as sketched.

The degree of motion is dependent on the diameter, length of live hose and the radius. Hoses that are more flexible because of more corrugations per foot, will accept greater displacements for a given configuration.

It is not practical in the larger diameters as the bend radii become large and the configuration takes too much space, because of what is lost to the semicircle at the bottom. Typical bend radii are as follows for intermittent flexing. A fixed bend could be tighter.



LOOP- UP AND DOWN MOTION

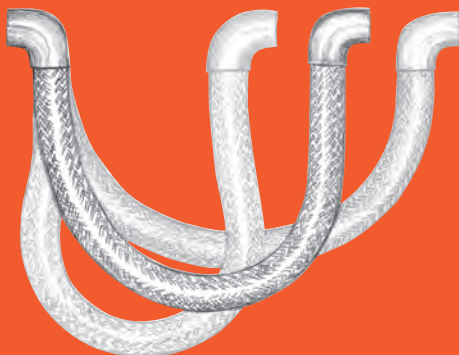

LOOP- IN AND OUT MOTION

Hose Diameter (in) (mm)	Bend Radius (in) (mm)	Hose Diameter (in) (mm)	Bend Radius (in) (mm)
1/2 15	6 1/2 165	6 150	28 700
3/4 20	8 1/4 206	8 200	34 850
1 25	9 3/4 244	10 250	45 1125
1 1/4 30	11 275	12 300	66 1650
1 1/2 40	12 300	14 350	77 1925
2 50	15 375	16 400	88 2200
2 1/2 65	16 400	18 450	100 2500
3 80	17 1/2 438	20 500	108 2700
4 100	19 3/4 494	24 600	135 3375
5 125	23 575	30 750	165 4125

As a 6" diameter hose would have a 56" diameter semicircle at the bottom, plus the vertical legs, you can see the problem.

PARALLEL LEGS

Since the in and out motion is normally the most important, it became common practice to substitute a 180° elbow at the bottom to eliminate the space and cost of the bottom loop. The legs can move up and down awkwardly, and in a walking motion all determined by the live hose length and flexibility.

Parallel pipe line loops cannot nest in the same plane without changing the 180° return to two 90° with a straight length of pipe between. Rather than working from stock, every nesting location becomes special order.

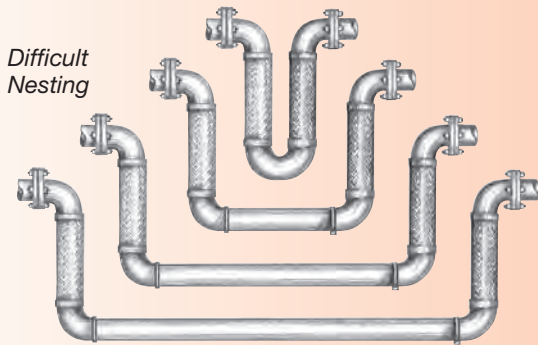

ADDITIONAL HORIZONTAL HOSE

Another market variation is the introduction of a third flexible hose between two 90° elbows in place of the 180° return or the straight pipe. This third element is effective but costly, and does not solve nesting problems either, unless smaller pipes are nested within larger ones or the horizontal flexible hose is lengthened. Once again, special order.

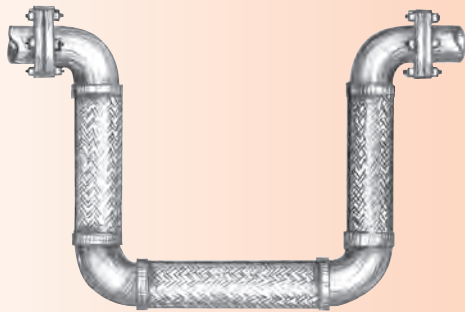

90° VEE

The next approach was the introduction of a 90° Vee. Up and down motion is improved, but opening and closing the Vee suffers.

We liked the general concept primarily because of the nesting, but did not want to suffer so great a loss of motion in compression or extension.

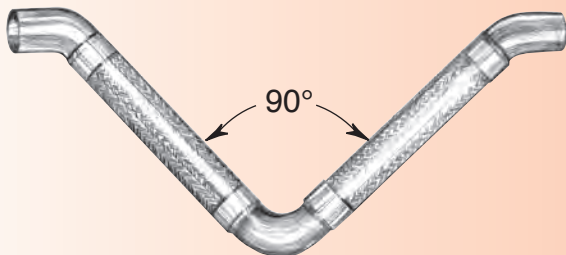

In fairness to others, we should note that all these hose designs can be made to work, if the hoses are made long enough to keep stress within acceptable limits for the stated movements.

MASON'S 60° VEE

Almost anyone with an engineering or mathematical background, and especially those of us who were manual mechanical draftsmen, think of the 30°, 60°, 90° triangle as the cornerstone of countless designs. When you put two of them together, as illustrated, the upside-down apex becomes 60° and this makes for an equilateral triangle. What a great configuration! All engineers with developed instincts know when a design looks right, it is often the solution, even without the mathematics. These simple sketches became the basis of our design.



The elements move more easily both toward and away from each other, up and down, and transversely. All movements are dependent on the length of the legs. They are great for nesting, and the space between the fittings takes less space than the 45° configuration with the same length of live hose.

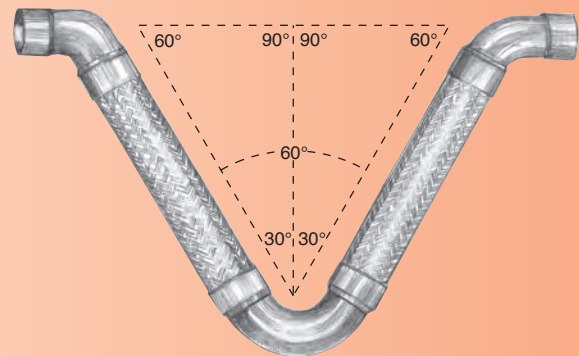

So far our competitors do not do it this way. Perhaps they never thought of it or they related to standard 45°, 90° and 180° fittings only. We studied the advantages and found a way to manufacture 60° and 120° fittings.

It is very difficult to publish all the nesting capabilities, but in one plane, a typical layout could be as shown below.

This illustration is just to suggest the idea and put your imagination to work. Send us your problems and let us work them out with you.

While all our configurations can be nested, it is very difficult for the firms with parallel legs, as mentioned earlier. Customization of parallel leg designs takes time and increases cost. In most cases, our product comes right out of stock, and fits the application.

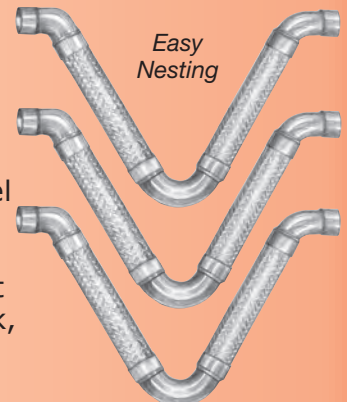

60° VEE MOVEMENTS WHEN INSTALLED VERTICALLY

4" Pipe Size

The following photographs show movement in all planes @ 100 psi. The pointer indicates movement.

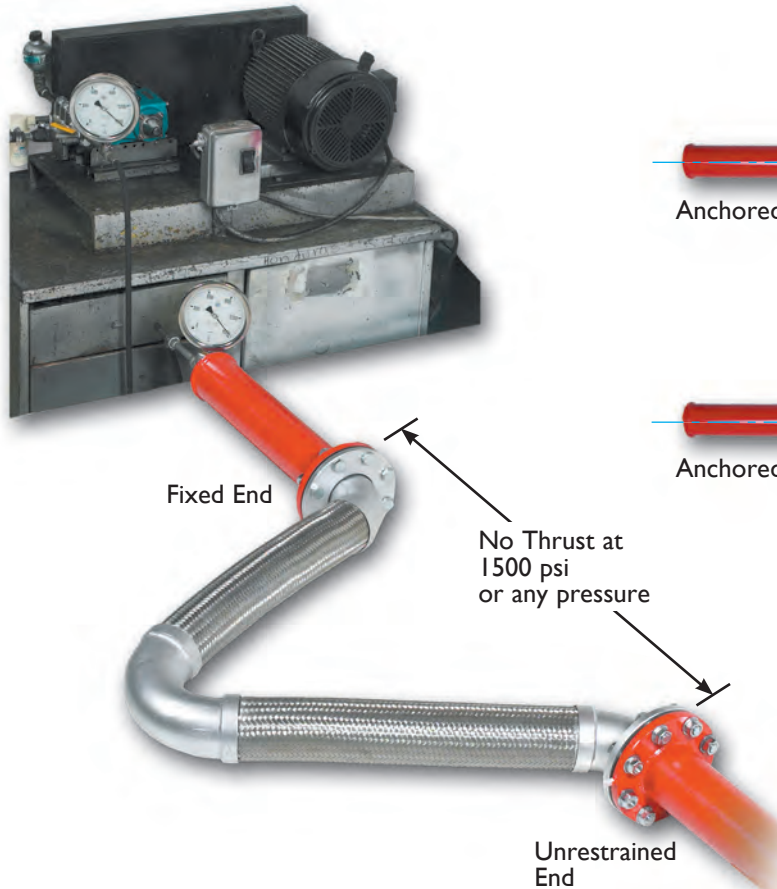
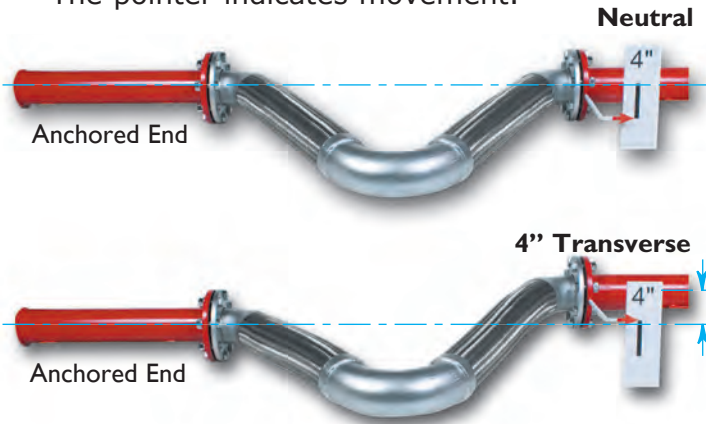

4" DOUBLE BRAIDED VEE PRESSURE TEST

Pressure test discontinued at 1500 psi. No Failure.

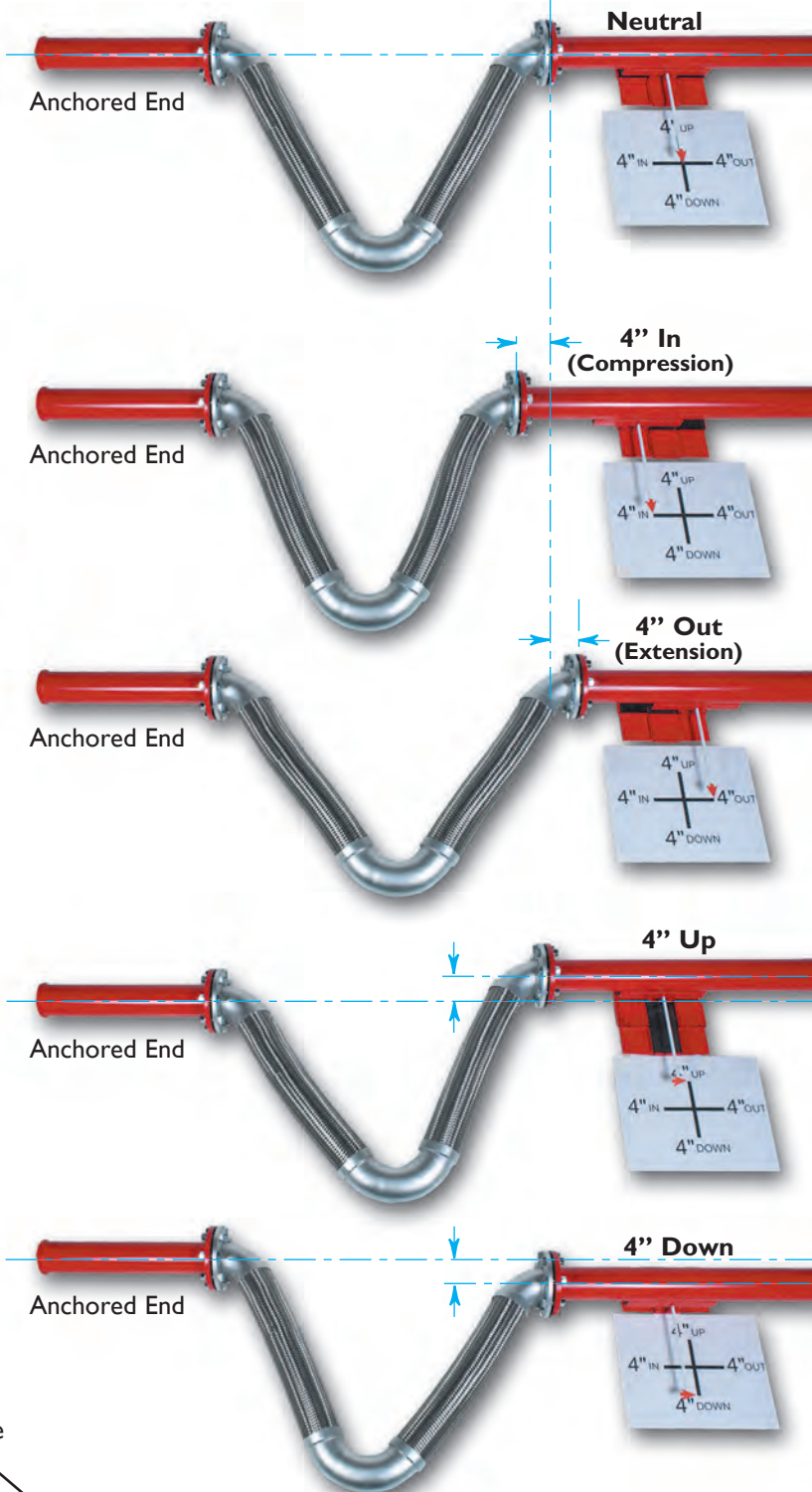

Our flanged vees have floating flanges at each end. When space is tight, the design allows for rotation to any angle to avoid obstacles like adjacent piping or ductwork. This is very important, particularly in the larger diameters where the legs become quite long.

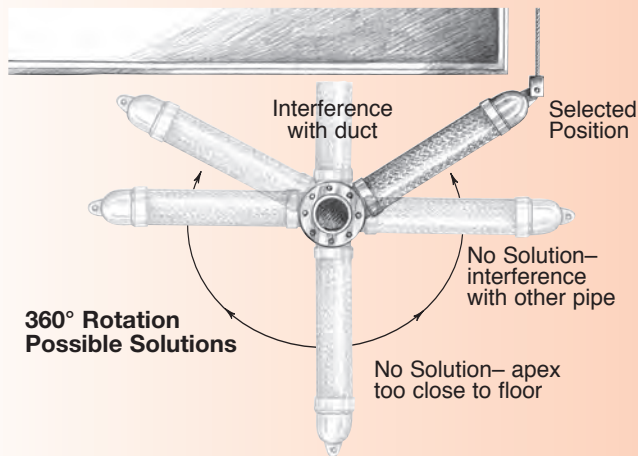

Our standard vee allows for 4" of seismic motion in all directions. The design is very conservative and in expansion locations with no change to the standard product we agree to 6" movements, when the movement is axial compression and extension.

Seismic applications allow for movement of adjacent sections of a structure at building joints or occasionally where piping goes from one building to another. The Vee is anchored close to and on either side of the separation. When it is between adjacent buildings, the location of the anchors depends on the space between the buildings and the rigidity of the pipe. The Vee may be in the space between buildings with a pipe anchor in each building or anchored in one building and guided in the other with an anchor further down.

Sometimes if the Vee is used to allow for expansion and contraction as well, one side is anchored and the other guided, provided there is more than one guide and there is an anchor at the end of the movement run.

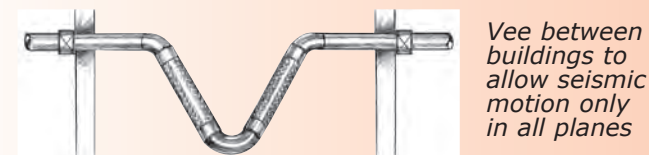

Common configuration across building expansion joints for seismic motion only in all planes

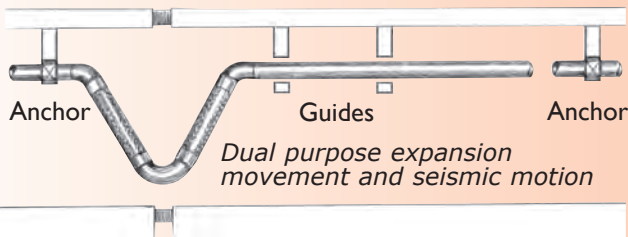
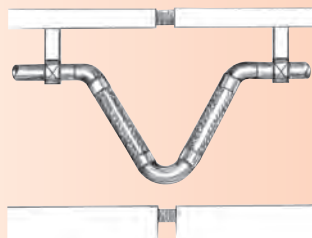

Let us help you with these layouts in the design stage, or just specify the Vee's and their function and we will submit layouts, as part of our certifications.

Simple internally pressurized or externally pressurized housed bellows were the only seamless solutions to thermal expansion in straight pipe runs for a very long time. While the force needed to move these configurations is not high, the pressure thrust is approximately equal to the projected area of the expansion joint to the center of the corrugations multiplied by the pressure. If it is a housed expansion joint, the internal area of the external housing is the reference.

It would take two 22,000 lbs. pipe anchors to resist the thrust and overcome the spring rate of a 10" diameter 150psi stainless steel bellows moving six inches. Finding this structural capacity is very difficult.

There is no thrust when a Vee is used in place of the bellows because the braid tightens and takes both. The six inch motion is taken by displacing each leg three inches and the force to do this is only 3300 lbs. as shown on page 7 of Test Bulletin VT-32. $3300/22000 \times 100 = 15\%$ of the bellows anchorage and much easier to work with structurally.

The following resistances are typical. For a comprehensive view of the complete Vee hose test data, consult Test Bulletin VT-32.

Stainless Vee Hose Size in (mm)	Corrugations per foot (meter)	Live Length of Braid & Hose inches (mm)	Axial Resistance for 4"(100mm) Displacement at 100psi (7.0 kg/cm ²) pounds (kgs)	
1/2 15	92 302	14 350	4	1.8
3/4 20	80 262	15 375	3	1.5
1 25	72 236	16 400	4	1.8
1 1/4 30	67 220	17 425	7	3.2
1 1/2 35	63 207	19 475	8	3.6
2 50	58 190	20 500	24	10.9
2 1/2 65	48 157	22 550	79	35.8
3 75	46 151	24 600	85	38.6
4 100	32 105	26 650	105	47.6
5 125	29 95	30 750	140	63.5
6 150	25 82	33 825	430	195
8 200	23 75	36 900	1300	590
10 250	21 69	42 1050	2200	998
12 300	20 66	48 1200	2250	1021

Even adding 50% to these numbers allows for relatively small anchors.

We do recommend guides as a better way to assure long life. Other companies are less conservative, but guides are not expensive, and the money is well spent.

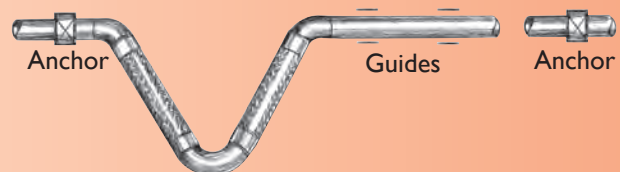

The pages that follow provide data on all of our stock 60° Vee's.

If you would like to specify them, please use the description on the following page.

SPECIFICATION:

Piping and/or equipment connections shall be protected against seismic movement failure by the insertion of flexible hose and braid Vee assemblies rated for ±4" (100mm) seismic motion in all planes. Should the application include ±6" (150 mm) thermal movement, the Vee shall be installed so the thermal movement is axial.

All submittals shall include a recognized test report, covering the full range of the specified movements at the operating pressures. Forces required to move the

Veess shall not exceed the Mason tabulated values below. Veess shall have a minimum burst pressure of four times their rated pressure. Veess in steel lines shall have stainless hose and braid. Copper lines, bronze hose and braid. Guiding and anchoring shall be as recommended by the manufacturer. 60° Veess shall be as manufactured by Mason Industries, Inc. Submittals shall include Movement-Force Test Reports.

AXIAL FORCE OF DISPLACEMENT for 6" MOVEMENT All Force Columns are in Pounds Lbs / 2.2 = Kilograms

Pressure (psi)	STAINLESS VEE SIZE								Pressure (psi)	Size 4" Force	Pressure (psi)	Size		Pressure (psi)	Size 8" Force	Pressure (psi)	Size	
	1/2"	3/4"	1"	1 1/4"	1 1/2"	2"	2 1/2"	3"				Force	5"				6"	Force
50	4	4	5	8	9	22	60	75	50	90	50	230	350	50	1200	50	1900	1900
100	5	4	6	12	13	28	90	120	100	140	100	240	520	100	1650	100	2700	2800
150	5	5	7	17	18	38	125	160	150	200	150	370	660	150	2200	150	3300	3400
200	5	6	9	21	22	44	160	200	200	290	200	400	850	180	2500	170	3700	3750
250	5	7	10	26	27	54	190	280	230	290								

AXIAL FORCE OF DISPLACEMENT for 6" MOVEMENT All Force Columns are in Pounds Lbs / 2.2 = Kilograms

Pressure (psi)	COPPER VEE SIZE								
	1/2"	3/4"	1"	1 1/4"	1 1/2"	2"	2 1/2"	3"	4"
50	4	6	7	13	13	25	80	90	140
100	5	7	8	18	24	40	120	150	230
175	5	9	12	25	38	63	170	230	350



VERTICAL VFL INSTALLATION (Apex Near Ceiling)

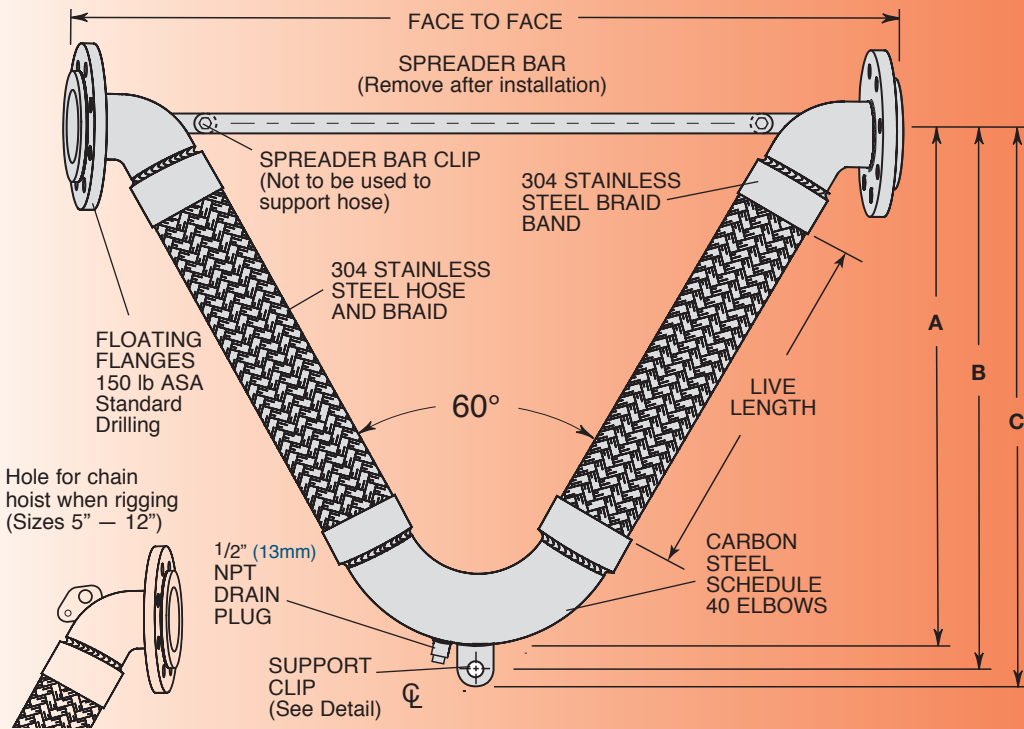

CARBON STEEL PLATE FLANGES

Pipe Size (in)	Pipe Size (mm)	Flange Thickness (in)	Flange Thickness (mm)
2 thru 4	50 thru 100	5/8	16
5 thru 6	125 thru 150	3/4	19
8 thru 12	200 thru 300	1	25



SUPPORT CLIP

Pipe Size (in)	Pipe Size (mm)	SUPPORT CLIP Hole Diameter (in)	SUPPORT CLIP Hole Diameter (mm)	Thickness (in)	Thickness (mm)
2	50	1/2	13	1/4	6
2 1/2	63	5/8	16	1/4	6
3	75	5/8	16	1/4	6
4	100	3/4	19	3/8	9
5	125	3/4	19	3/8	9
6	150	7/8	22	3/8	9
8	200	1	25	1/2	13
10	250	1	25	1/2	13
12	300	1 1/8	28	1/2	13

RATED PRESSURES @ ELEVATED TEMPERATURES (psi) (kg/cm²)

Pipe Size (in)	Pipe Size (mm)	250°F 121°C Factor 0.92	350°F 176°C Factor 0.86	450°F 232°C Factor 0.81
2	50	330	23	290
2 1/2	65	270	19	235
3	80	260	18	230
4	100	210	15	190
5	125	190	13	170
6	150	190	13	170
8	200	170	11	150
10	250	160	11	140
12	300	160	11	140

SATURATED STEAM RECOMMENDED PRESSURE LIMITS

Pipe Size (in)	Pipe Size (mm)	Max Gauge (psi)	Max Gauge (kg/cm ²)	Temp Reference (F)	Temp Reference (°C)
2	50	150	11	362	183
2 1/2	65	125	9	355	179
3	80	125	9	355	179
4	100	125	9	355	179
5	125	100	7	337	169
6	150	100	7	337	169
8	200	75	5	320	160
10	250	60	4	307	153
12	300	60	4	307	153

Our steam service ratings are very low in the interest of safety although our 70°F (21°C) pressure ratings are as high or higher than our competitors. All locations where failure could lead to personal injury or suffocation must be avoided. In dangerous locations we suggest housed expansion joints, solid loops, ball joints, packed devices etc. rather than thin walled flexible products regardless of manufacturer.

Consult factory with full location description as well as service conditions for higher pressure or temperature applications.

304 SS can be used up to 850°F (454°C) in applications such as engine exhaust.

When using VFL products in copper or brass water or steam systems, dielectric fittings must be used on each end to prevent leakage from galvanic action.

VFL DIMENSIONS AND PRESSURE RATINGS (British Units) ±4" ALL DIRECTIONAL SEISMIC MOVEMENT

Type	Pipe Size & Face to Face† (in)	Live Length (in)	Corrugations per foot	A (in)	B (in)	C (in)	Rated Pressure @70°F†† (psi)
VFL	2 X 33	20	58	227/8	237/8	245/8	360
VFL	2 1/2 X 37	22	48	26	27	273/4	290
VFL	3 X 42	24	46	287/8	301/8	311/8	280
VFL	4 X 49	26	32	321/2	333/4	347/8	225
VFL	5 X 58	30	29	38	391/4	401/2	200
VFL	6 X 66	33	25	425/8	441/8	453/8	200
VFL	8 X 80	36	23	491/4	503/4	52	180
VFL	10 X 96	42	21	581/2	601/4	613/4	170
VFL	12 X 112	48	20	673/4	691/2	71	170°

VFL DIMENSIONS AND PRESSURE RATINGS (Metric Units) ±102mm ALL DIRECTIONAL SEISMIC MOVEMENT

Type	Pipe Size & Face to Face† (mm)	Live Length (mm)	Corrugations per meter	A (mm)	B (mm)	C (mm)	Rated Pressure @21°C†† (kg/cm ²)
VFL	50 X 838	508	190	603	613	629	25
VFL	65 X 940	559	157	660	689	711	20
VFL	80 X 1067	610	151	733	762	781	19
VFL	100 X 1245	660	105	826	857	886	16
VFL	125 X 1473	762	95	965	1010	1026	14
VFL	150 X 1676	838	82	1083	1118	1149	14
VFL	200 X 2032	914	75	1251	1289	1324	12
VFL	250 X 2438	1067	69	1486	1524	1559	12
VFL	300 X 2849	1219	66	1721	1762	1797	12°

†Face to Face Tolerances: Sizes 2" - 4" (50 - 100mm), ±1/4" (6mm); Sizes 5" - 8" (125 - 200mm), ±3/8" (9mm); Sizes 10" (250mm) and larger, ±1/2" (13mm). ††Minimum Burst is four times the Rated Pressure. Safety factor of 4. °Size 12" (300mm) has double braid.

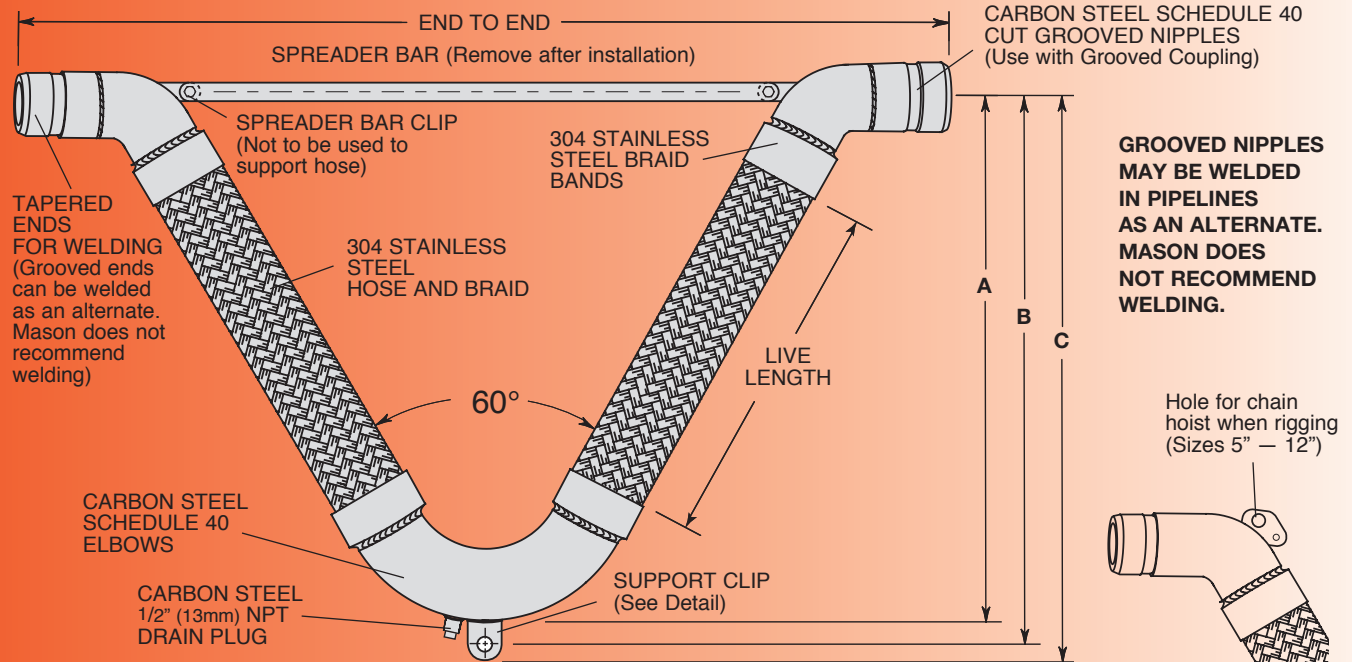

Drain Plugs are often attached to drain or steam trap for blow down or drainage.

RATED PRESSURES @ ELEVATED TEMPERATURES (psi) (kg/cm²)

Pipe Size (in) (mm)	250°F 121°C Factor 0.92	350°F 176°C Factor 0.86	450°F 232°C Factor 0.81
2 50	330 23	310 21	290 20
2 1/2 65	270 19	250 17	235 16
3 80	260 18	240 16	230 16
4 100	210 15	200 14	190 13
5 125	190 13	180 12	170 11
6 150	190 13	180 12	170 11
8 200	170 11	160 11	150 10
10 250	160 11	150 10	140 9
12 300	160 11	150 10	140 9

SATURATED STEAM RECOMMENDED PRESSURE LIMITS

Pipe Size (in) (mm)	Max Gauge (psi) (kg/cm ²)	Temp Reference (F) (°C)
2 50	150 11	362 183
2 1/2 65	125 9	355 179
3 80	125 9	355 179
4 100	125 9	355 179
5 125	100 7	337 169
6 150	100 7	337 169
8 200	75 5	320 160
10 250	60 4	307 153
12 300	60 4	307 153

Our steam service ratings are very low in the interest of safety although our 70°F (21°C) pressure ratings are as high or higher than our competitors. All locations where failure could lead to personal injury or suffocation must be avoided. In dangerous locations we suggest housed expansion joints, solid loops, ball joints, packed devices etc. rather than thin walled flexible products regardless of manufacturer.

Consult factory with full location description as well as service conditions for higher pressure or temperature applications.

304 SS can be used up to 850°F (454°C) in applications such as engine exhaust.

When using VGN products in copper or brass water or steam systems, dielectric fittings must be used on each end to prevent leakage from galvanic action.

VGN DIMENSIONS AND PRESSURE RATINGS (British Units)
±4" ALL DIRECTIONAL SEISMIC MOVEMENT

Type	Pipe Size & End to End [†] (in)	Live Length (in)	Corrugations per foot	A (in)	B (in)	C (in)	Rated Pressure @70°F ^{††} (psi)
VGN	2 X 36	20	58	23 1/4	24 1/4	25	360
VGN	2 1/2 X 41	22	48	26	27	27 3/4	290
VGN	3 X 46	24	46	28 7/8	30 1/8	31 1/8	280
VGN	4 X 55	26	32	32 1/2	33 3/4	34 3/4	225
VGN	5 X 64	30	29	38	39 1/2	40 1/2	200
VGN	6 X 72	33	25	42 5/8	44 1/8	45 3/8	200
VGN	8 X 86	36	23	49 1/4	50 3/4	52	180
VGN	10 X 105	42	21	58 1/2	60 1/4	61 3/4	170
VGN	12 X 120	48	20	67 3/4	69 1/2	71	170 [°]

VGN DIMENSIONS AND PRESSURE RATINGS (Metric Units)
±102mm ALL DIRECTIONAL SEISMIC MOVEMENT

Type	Pipe Size & End to End [†] (mm)	Live Length (mm)	Corrugations per meter	A (mm)	B (mm)	C (mm)	Rated Pressure @21°C ^{††} (kg/cm ²)
VGN	50 X 914	508	190	591	616	635	25
VGN	65 X 1041	559	157	660	688	700	20
VGN	80 X 1168	610	151	733	766	792	19
VGN	100 X 1397	660	105	826	857	883	16
VGN	125 X 1626	762	95	965	1003	1029	14
VGN	150 X 1829	838	82	1083	1121	1153	14
VGN	200 X 2184	914	75	1251	1289	1321	12
VGN	250 X 2667	1067	69	1486	1530	1568	12
VGN	300 X 3048	1219	66	1721	1765	1803	12 [°]

[†]End to End Tolerances: Sizes 2" - 4" (50 - 100mm), ±1/4" (6mm); Sizes 5" - 8" (125 - 200mm), ±3/8" (9mm); Sizes 10" (250mm) and larger, ±1/2" (13mm). ^{††}Minimum Burst is four times the Rated Pressure. Safety factor of 4. [°]Size 12" (300mm) has double braid.

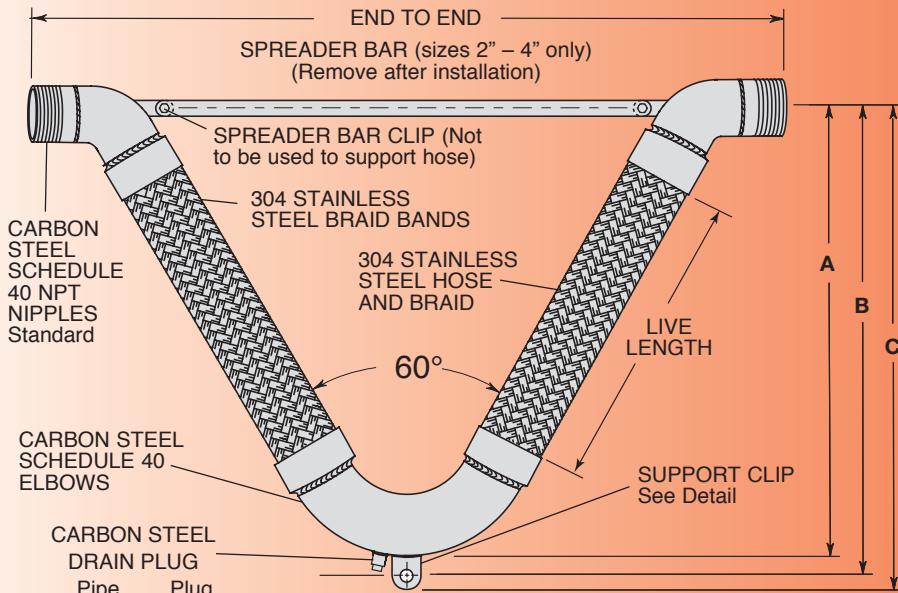

SUPPORT CLIP

Pipe Size (in) (mm)	SUPPORT CLIP Hole Diameter (in) (mm)	Thickness (in) (mm)
1/2 15	1/2 13	1/8 3
3/4 20	1/2 13	1/8 3
1 25	1/2 13	1/8 3
1 1/4 32	1/2 13	1/8 3
1 1/2 40	1/2 13	1/8 3
2 50	5/8 16	1/8 3
2 1/2 65	5/8 16	1/8 3
3 80	3/4 19	1/8 3
4 100	3/4 19	1/8 3

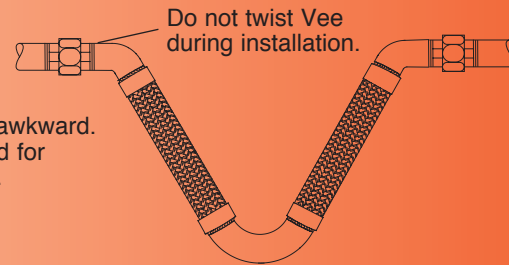

Installation using Couplings is awkward. Unions are very much preferred for easier installation and removal.

RATED PRESSURES @ ELEVATED TEMPERATURES (psi) (kg/cm²)

Pipe Size (in) (mm)	250°F 121°C Factor 0.92	350°F 176°C Factor 0.86	450°F 232°C Factor 0.81
1/2 15	1010 69	950 59	890 61
3/4 20	640 44	600 41	570 39
1 25	530 36	500 34	470 32
1 1/4 32	460 32	430 30	400 28
1 1/2 40	400 28	370 26	350 24
2 50	330 23	310 21	290 20
2 1/2 65	270 19	250 17	235 16
3 80	260 18	240 16	230 16
4 100	210 15	200 14	190 13

SATURATED STEAM RECOMMENDED PRESSURE LIMITS

Pipe Size (in) (mm)	Max Gauge (psi) (kg/cm ²)	Temp Reference (°F) (°C)
1/2 15	200 14	387 197
3/4 20	200 14	387 197
1 25	150 11	362 183
1 1/4 32	150 11	362 183
1 1/2 40	150 11	362 183
2 50	150 11	362 183
2 1/2 65	125 9	355 179
3 80	125 9	355 179
4 100	125 9	355 179

Our steam service ratings are very low in the interest of safety although our 70°F (21°C) pressure ratings are as high or higher than our competitors. All locations where failure could lead to personal injury or suffocation must be avoided. In dangerous locations we suggest housed expansion joints, solid loops, ball joints, packed devices etc. rather than thin walled flexible products regardless of manufacturer.

Consult factory with full location description as well as service conditions for higher pressure or temperature applications.

304 SS can be used up to 850°F (454°C) in applications such as engine exhaust.

When using VMN products in copper or brass water or steam systems, dielectric fittings must be used on each end to prevent leakage from galvanic action.

VMN DIMENSIONS AND PRESSURE RATINGS (British Units) +4" ALL DIRECTIONAL SEISMIC MOVEMENT

Type	Pipe Size & End to End [†] (in)	Live Length (in)	Corrugations per foot	A (in)	B (in)	C (in)	Rated Pressure @70°F ^{††} (psi)
VMN	1/2 X 23 1/2	14	92	15 1/8	15 7/8	16 3/8	1100
VMN	3/4 X 24	15	80	16 1/8	16 7/8	17 3/8	700
VMN	1 X 26	16	72	17 7/8	18 5/8	19 1/8	580
VMN	1 1/4 X 29	17	67	18 1/2	19 1/4	19 3/4	500
VMN	1 1/2 X 32	19	63	20 3/4	21 1/2	22	430
VMN	2 X 36	20	58	23 1/4	24 1/4	25	360
VMN	2 1/2 X 41	22	48	26	27	27 3/4	290
VMN	3 X 46	24	46	28 7/8	30 1/8	31 1/8	280
VMN	4 X 55	26	32	32 1/2	33 3/4	34 3/4	225

VMN DIMENSIONS AND PRESSURE RATINGS (Metric Units) ±102mm ALL DIRECTIONAL SEISMIC MOVEMENT

Type	Pipe Size & End to End [†] (mm)	Live Length (mm)	Corrugations per meter	A (mm)	B (mm)	C (mm)	Rated Pressure @21°C ^{††} (kg/cm ²)
VMN	15 X 597	356	302	384	403	416	76
VMN	20 X 610	381	262	410	429	441	48
VMN	25 X 660	406	236	454	473	486	40
VMN	32 X 737	432	220	470	489	502	34
VMN	40 X 813	483	207	527	546	559	30
VMN	50 X 914	508	190	591	616	635	25
VMN	65 X 1041	559	157	660	686	705	20
VMN	80 X 1168	610	151	733	765	791	19
VMN	100 X 1397	660	105	826	857	883	16

[†]End to End Tolerances: All Sizes, ±1/4"(6mm) ^{††}Minimum Burst is four times the Rated Pressure. Safety factor of 4.

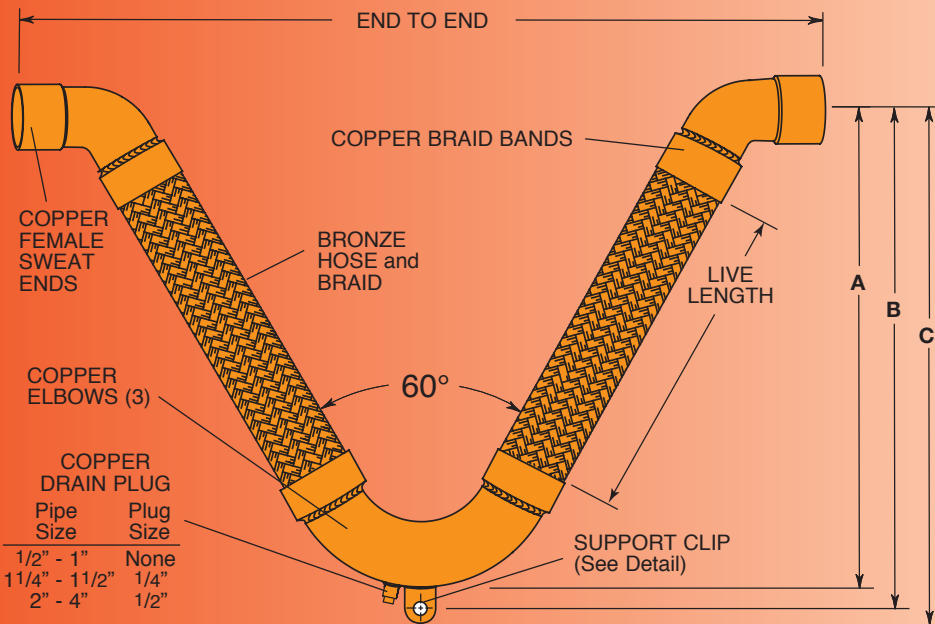

Pipe Size	Plug Size
1/2" - 1"	None
1 1/4" - 1 1/2"	1/4"
2" - 4"	1/2"

Drain Plugs are often attached to drain for blow down or drainage.

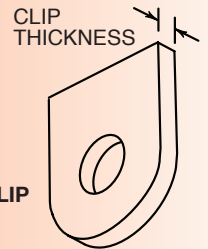

**SUPPORT CLIP
DETAIL**

SUPPORT CLIP

Pipe Size (in) (mm)	SUPPORT CLIP Hole Diameter (in) (mm)	Thickness (in) (mm)
1/2 15	1/2 16	1/8 3
3/4 20	1/2 16	1/8 3
1 25	1/2 16	1/8 3
1 1/4 32	1/2 16	1/8 3
1 1/2 40	1/2 16	1/8 3
2 50	5/8 16	1/8 3
2 1/2 65	5/8 16	1/8 3
3 80	3/4 19	1/8 3
4 100	3/4 19	1/8 3

INSTALLATION INSTRUCTIONS for VCPSB

1. Thoroughly clean male and female ends using steel wool and steel brushes.
2. Apply flux.
3. Wrap base of copper fitting on connector and 2" (50mm) of the braid with a wet cloth to prevent overheating during soldering.
4. Direct the torch away from the base of the copper fitting and braided section. Avoid contact of the flame with the base of the copper fitting and braid. Heat end of copper fitting for proper flow of silver solder. Silver solder flows at approximately 430°F (221°C).
5. Do not use brazing rod or other higher temperature techniques in place of the silver solder. Overheating will cause leaks.
6. Remove wet rag and remove all soldering flux immediately after installation. Flux chlorides will cause premature failure of hose assembly.

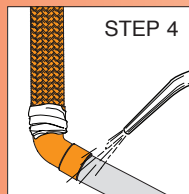
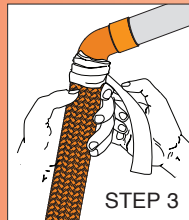

RATED PRESSURES @ ELEVATED TEMPERATURES (psi) (kg/cm²)

Hose Size	150°F 66°C	300°F 149°C	400°F 204°C
	Factor 0.92	Factor 0.83	Factor 0.78
All Sizes	160 11	145 10	135 9

When using VCPSB products in stainless steel water systems, dielectric unions must be used on each end to prevent leakage from galvanic action.

**VCPSB DIMENSIONS AND PRESSURE RATINGS (British Units)
+4" ALL DIRECTIONAL SEISMIC MOVEMENT**

Type	Tubing* Size & End to End† (in)	Live Length (in)	Corrugations per foot	A (in)	B (in)	C (in)	Rated Pressure @70°F†† (psi)
VCPSB	1/2 x 215/8	14	88	15	153/4	161/4	175
VCPSB	3/4 x 221/8	15	60	153/4	161/2	17	175
VCPSB	1 x 243/8	16	50	17	173/4	181/4	175
VCPSB	1 1/4 x 283/4	17	47	183/8	191/8	195/8	175
VCPSB	1 1/2 x 303/8	19	44	205/8	213/8	217/8	175
VCPSB	2 x 373/4	20	42	221/2	231/2	241/4	175
VCPSB	2 1/2 x 401/8	22	30	257/8	267/8	275/8	175
VCPSB	3 x 451/8	24	29	285/8	297/8	307/8	175
VCPSB	4 x 533/8	26	28	323/8	335/8	345/8	175°

**VCPSB DIMENSIONS AND PRESSURE RATINGS (Metric Units)
±102mm ALL DIRECTIONAL SEISMIC MOVEMENT**

Type	Tubing* Size & End to End† (mm)	Live Length (mm)	Corrugations per meter	A (mm)	B (mm)	C (mm)	Rated Pressure @21°C†† (kg/cm²)
VCPSB	15 x 549	356	289	381	400	413	12
VCPSB	20 x 562	381	197	400	419	432	12
VCPSB	25 x 594	406	164	432	451	464	12
VCPSB	32 x 730	432	154	467	486	498	12
VCPSB	40 x 772	483	144	524	543	556	12
VCPSB	50 x 959	508	138	572	597	616	12
VCPSB	65 x 1019	559	98	657	683	702	12
VCPSB	80 x 1146	610	95	727	759	784	12
VCPSB	100 x 1356	660	92	822	854	879	12 °

*Female end fits over copper tubing, e.g. 1/2 x 21 (15 x 525mm) fits over 1/2" (15mm) tubing.

†End to End Tolerances: All Sizes, ±1/4" (6mm) ††Minimum Burst is four times the Rated Pressure. Safety factor of 4.

°Size 4" (100mm) has double braid.

CSA Series of Braided Hose

Everyone is concerned when installing flexible hose in flammable gas or liquid lines because of the risk of both asphyxiation and fire. Approved by the CSA, the successor to the American Gas Association, and complying with UL 536 provides that assurance. Tests include vibration 300 hours at 15 Hz, 90° bends at rated pressure @ 10 cpm for 20,000 cycles, elongation and tension, 450°F (232°C) for 100 hours as well as flame resistance. All of our standard hoses 1/2" through

4" diameter passed and can be used in straight, looped or Vee configurations. However, in addition to the general UL approval, all specific hoses must be rechecked with an approved thread gauge, if threaded, and retested to 50% above rated pressure using water or rated pressure using air. It must be clearly identified as a Mason product and tagged with maximum pressure rating and minimum bend radius.

CSAVMN EQUI-V HOSE with THREADED NIPPLES

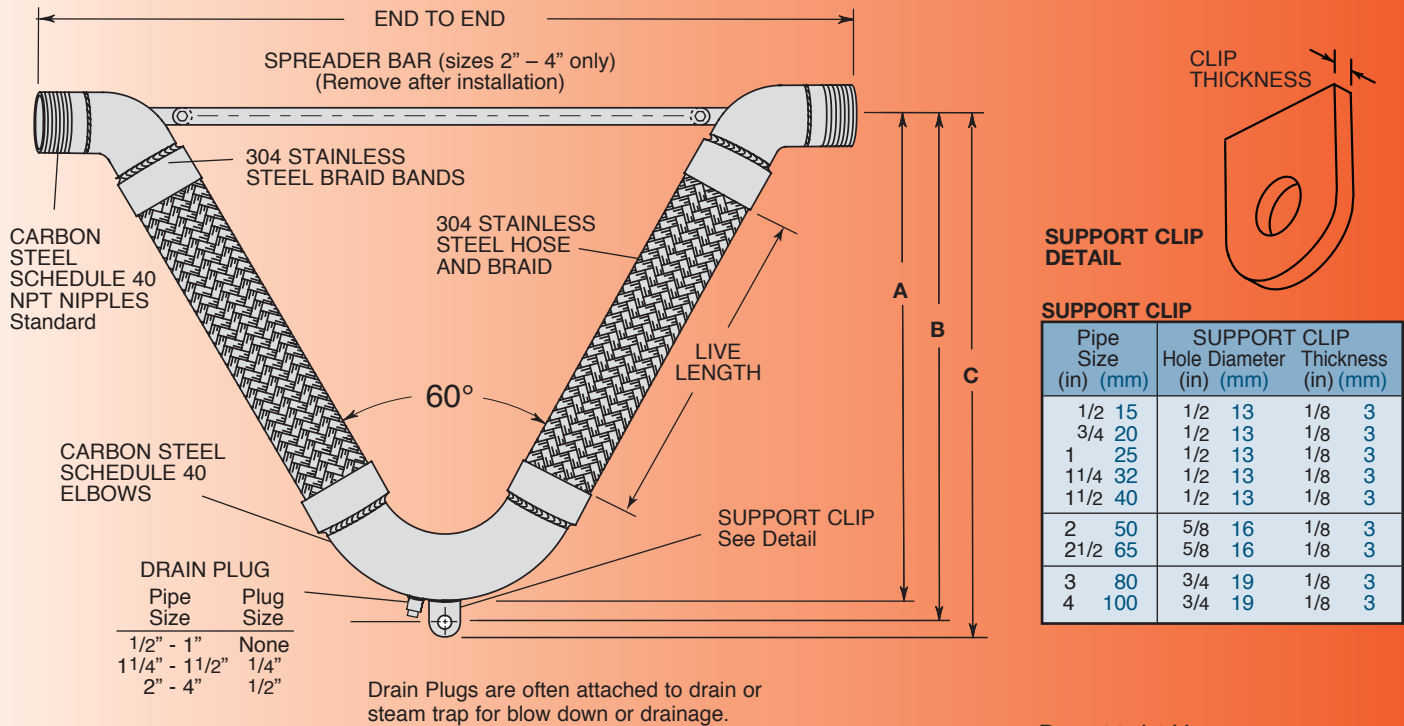

Pipe Size	Plug Size
1/2" - 1"	None
1 1/4" - 1 1/2"	1/4"
2" - 4"	1/2"

Drain Plugs are often attached to drain or steam trap for blow down or drainage.



These assemblies have been "CSA" approved for use in gas pipelines. "CSA" is the current certification agency for gas industry products, assuming the authority formerly associated with the American Gas Association (AGA).

The Certification Report is #230720-1764990. This Certification meets all requirements of ANSI/UL #536- 1997 Standards for Flexible Metal Hose.

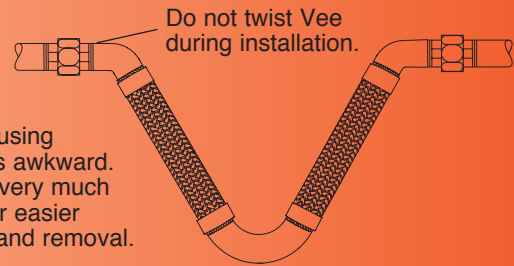

CSAVMN DIMENSIONS AND PRESSURE RATINGS (British Units) ±4" ALL DIRECTIONAL SEISMIC MOVEMENT

Pipe* Size & End to End† (in)	Live Length (in)	Corrugations per foot	A (in)	B (in)	C (in)	Rated Pressure @70°F (psi)	Min Burst Pressure (psi)	Safety Factor
1/2 X 23 1/2	14	92	15 1/8	15 7/8	16 3/8	175	4300	25
3/4 X 24	15	80	16 1/8	16 7/8	17 3/8	175	3168	18
1 X 26	16	72	17 7/8	18 5/8	19 1/8	175	3132	18
1 1/4 X 29	17	67	18 1/2	19 1/4	19 3/4	175	2656	15
1 1/2 X 32	19	63	20 3/4	21 1/2	22	175	2284	13
2 X 36	20	58	23 1/4	24 1/4	25	175	2120	12
2 1/2 X 41	22	48	26	27	27 3/4	175	1724	10
3 X 46	24	46	28 7/8	30 1/8	31 1/8	175	1564	9
4 X 55	26	32	32 1/2	33 3/4	34 3/4	175	1160	7

CSAVMN DIMENSIONS AND PRESSURE RATINGS (Metric Units) ±102mm ALL DIRECTIONAL SEISMIC MOVEMENT

Pipe* Size & End to End† (mm)	Live Length (mm)	Corrugations per meter	A (mm)	B (mm)	C (mm)	Rated Pressure @21°C (kg/cm²)	Min Burst Pressure (kg/cm²)	Safety Factor
15 X 597	356	302	384	403	416	12	302	25
20 X 610	381	262	410	429	441	12	222	18
25 X 660	406	236	454	473	486	12	220	18
32 X 737	432	220	470	489	502	12	186	15
40 X 813	483	207	527	546	559	12	160	13
50 X 914	508	190	591	616	635	12	149	12
65 X 1041	559	157	660	686	705	12	121	10
80 X 1168	610	151	733	765	791	12	109	9
100 X 1397	660	105	826	857	883	12	81	7

*End to End Tolerances: All Sizes, ±1/4"(6mm) ††Minimum Burst is four times the Rated Pressure. Safety factor of 4.

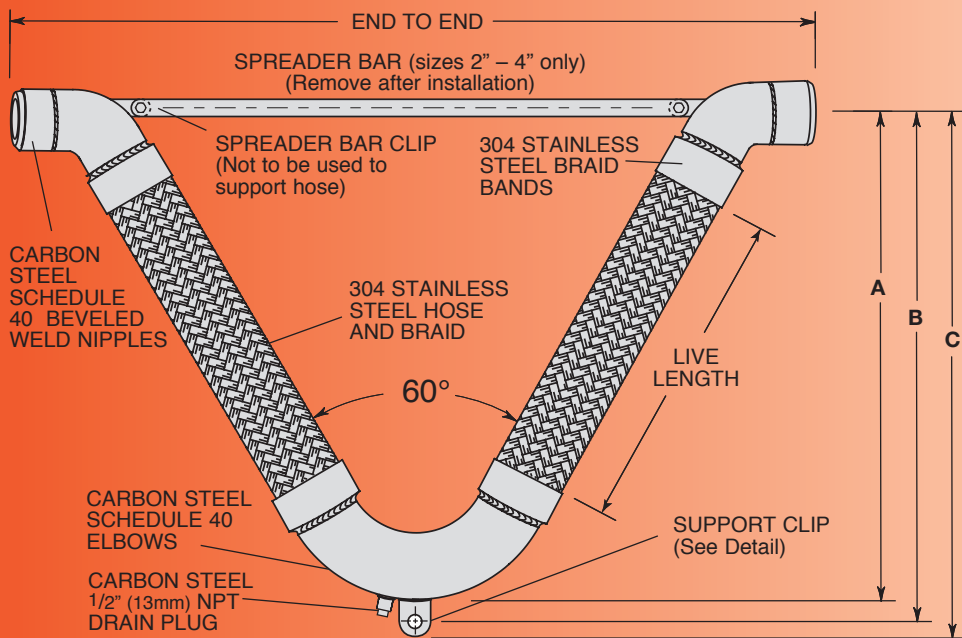

CSAVWN EQUI-V HOSE with WELD NIPPLES

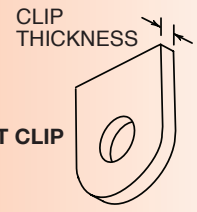

SUPPORT CLIP

Pipe Size (in) (mm)	Hole Diameter (in) (mm)	Thickness (in) (mm)
1/2 15	1/2 13	1/8 3
3/4 20	1/2 13	1/8 3
1 25	1/2 13	1/8 3
1 1/4 32	1/2 13	1/8 3
1 1/2 40	1/2 13	1/8 3
2 50	5/8 16	1/8 3
2 1/2 65	5/8 16	1/8 3
3 80	3/4 19	1/8 3
4 100	3/4 19	1/8 3

CSAVWN DIMENSIONS AND PRESSURE RATINGS (British Units) ±4" ALL DIRECTIONAL SEISMIC MOVEMENT

Pipe* Size & End to End† (in)	Live Length (in)	Corrugations per foot	A (in)	B (in)	C (in)	Rated Pressure @70°F (psi)	Min Burst Pressure (psi)	Safety Factor
1/2 X 21 1/2	14	92	15 1/8	15 7/8	16 3/4	175	4300	25
3/4 X 22	15	80	16 1/8	16 7/8	17 3/8	175	3168	18
1 X 24	16	72	17 7/8	18 5/8	19 1/8	175	3132	18
1 1/4 X 27	17	67	18 1/2	19 1/4	19 3/4	175	2656	15
1 1/2 X 30	19	63	20 3/4	21 1/2	22	175	2284	13
2 X 33 1/2	20	58	23 1/4	24 1/4	25	175	2120	12
2 1/2 X 38	22	48	26	27	27 3/4	175	1724	10
3 X 43	24	46	28 7/8	30 1/8	31 1/8	175	1564	9
4 X 52	26	32	32 1/2	33 3/4	34 3/4	175	1160	7

CSAVWN DIMENSIONS AND PRESSURE RATINGS (Metric Units) ±102mm ALL DIRECTIONAL SEISMIC MOVEMENT

Pipe* Size & End to End† (mm)	Live Length (mm)	Corrugations per meter	A (mm)	B (mm)	C (mm)	Rated Pressure @21°C (kg/cm²)	Min Burst Pressure (kg/cm²)	Safety Factor
15 X 546	356	302	384	403	416	12	302	25
20 X 559	381	262	410	429	441	12	222	18
25 X 610	406	236	454	473	486	12	220	18
32 X 686	432	220	470	489	502	12	186	15
40 X 762	483	207	527	546	559	12	160	13
50 X 851	508	190	591	616	635	12	149	12
65 X 965	559	157	660	686	705	12	121	10
80 X 1092	610	151	733	765	791	12	109	9
100 X 1321	660	105	826	857	883	12	81	7

*End to End Tolerances: All Sizes, ±1/4"(6mm)

CSAVFL EQUI-V HOSE with FLOATING FLANGES

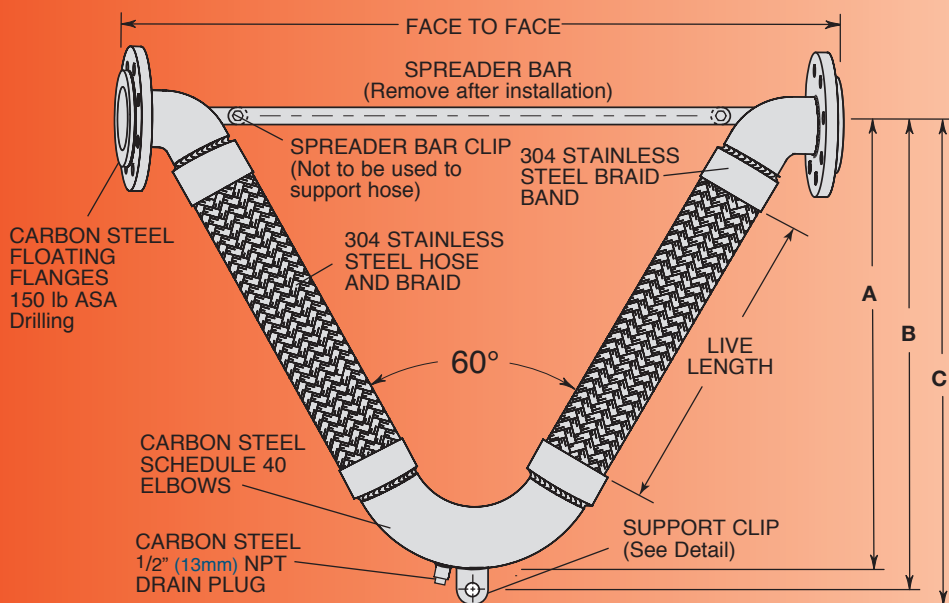

CARBON STEEL PLATE FLANGES

Pipe Size (in)	Flange Thickness (in) (mm)
2 thru 4	5/8 16



These assemblies have been "CSA" approved for use in gas pipelines. "CSA" is the current certification agency for gas industry products, assuming the authority formerly associated with the American Gas Association (AGA).

The Certification Report is #230720-1764990. This Certification meets all requirements of ANSI/UL #536- 1997 Standards for Flexible Metal Hose.

CSAVFL DIMENSIONS AND PRESSURE RATINGS (British Units) ±4" ALL DIRECTIONAL SEISMIC MOVEMENT

Pipe Size & Face to Face† (in)	Live Length (in)	Corrugations per foot	A (in)	B (in)	C (in)	Rated Pressure @70°F (psi)	Min Burst Pressure (psi)	Safety Factor
2 X 33	20	68	23 1/4	24 1/8	24 3/4	175	2120	12
2 1/2 X 37	22	56	26	27 1/8	28	175	1724	10
3 X 42	24	30	28 7/8	30	30 3/4	175	1564	9
4 X 49	26	29	32 1/2	33 3/4	34 7/8	175	1160	7

CSAVFL DIMENSIONS AND PRESSURE RATINGS (Metric Units) ±102mm ALL DIRECTIONAL SEISMIC MOVEMENT

Pipe Size & Face to Face† (mm)	Live Length (mm)	Corrugations per meter	A (mm)	B (mm)	C (mm)	Rated Pressure @70°F (kg/cm²)	Min Burst Pressure (kg/cm²)	Safety Factor
50 X 825	500	223	603	613	629	12	146	12
65 X 925	550	184	660	689	711	12	119	10
80 X 1050	600	98	733	762	781	12	108	9
100 X 1225	650	95	826	857	886	12	80	7

*Face to Face Tolerances: Sizes 2" - 4"(50 - 100mm), ±1/4"(6mm)

CSAVCPS EQUI-V HOSE with COPPER SWEAT ENDS

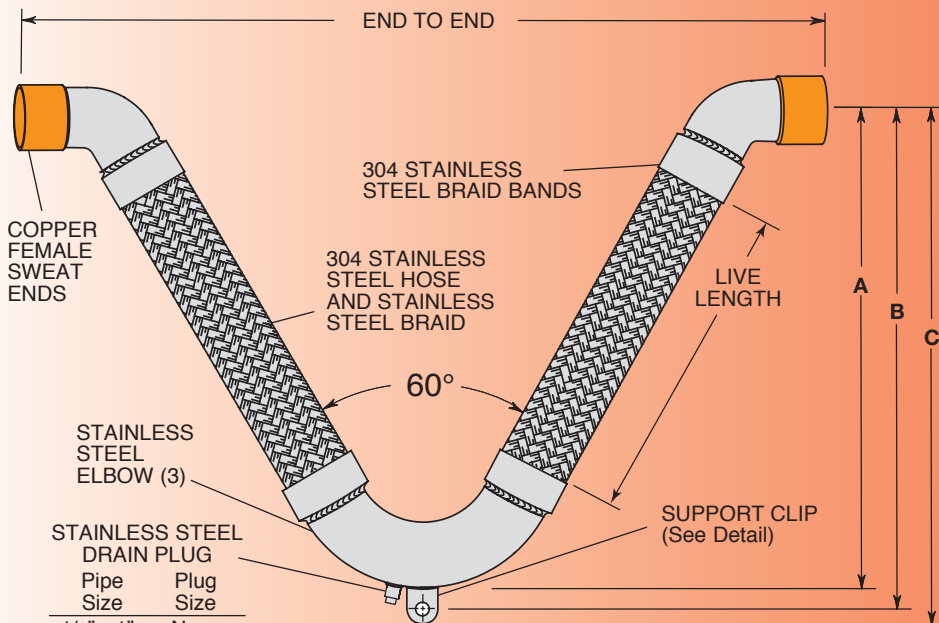

SUPPORT CLIP DETAIL

SUPPORT CLIP

Pipe Size (in)	Pipe Size (mm)	Hole Diameter (in)	Hole Diameter (mm)	Thickness (in)	Thickness (mm)
1/2	15	1/2	13	1/8	3
3/4	20	1/2	13	1/8	3
1	25	1/2	13	1/8	3
1 1/4	32	1/2	13	1/8	3
1 1/2	40	1/2	13	1/8	3
2	50	5/8	16	1/8	3
2 1/2	65	5/8	16	1/8	3
3	80	3/4	19	1/8	3
4	100	3/4	19	1/8	3

Pipe Size	Plug Size
1/2" - 1"	None
1 1/4" - 1 1/2"	1/4"
2" - 4"	1/2"

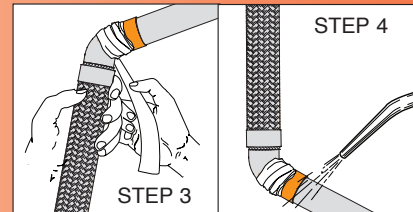

These assemblies have been "CSA" approved for use in gas pipelines. "CSA" is the current certification agency for gas industry products, assuming the authority formerly associated with the American Gas Association (AGA).

The Certification Report is #230720-1764990. This Certification meets all requirements of ANSI/UL #536- 1997 Standards for Flexible Metal Hose.

Use only in flammable gas pipelines.

INSTALLATION INSTRUCTIONS for CSAVCPS

1. Thoroughly clean male and female ends using steel wool and steel brushes.
2. Apply flux.
3. Wrap base of copper fitting on connector and 2" (50mm) of the elbow with a wet cloth to prevent overheating during soldering.
4. Direct the torch away from the base of the copper fitting and braided section. Avoid contact of the flame with the base of the copper fitting and braid. Heat end of copper fitting for proper flow of silver solder. Silver solder flows at approximately 430°F (221°C).
5. Do not use brazing rod or other higher temperature techniques in place of the silver solder. Overheating will cause leaks.
6. Remove wet rag and remove all soldering flux immediately after installation. Flux chlorides will cause premature failure of hose assembly.

CSAVCPS DIMENSIONS AND PRESSURE RATINGS (British Units)

±4" ALL DIRECTIONAL SEISMIC MOVEMENT

Tubeing* Size & End to End† (in)	Live Length (in)	Corrugations per foot	A (in)	B (in)	C (in)	Rated Pressure @70°F (psi)	Min Burst Pressure (psi)	Safety Factor
1/2 x 215/8	14	88	15	153/4	161/4	175	4300	25
3/4 x 221/8	15	60	153/4	161/2	17	175	3168	18
1 x 243/8	16	50	17	173/4	181/4	175	3132	18
1 1/4 x 283/4	17	47	183/8	191/8	195/8	175	2656	15
1 1/2 x 303/8	19	44	205/8	213/8	217/8	175	2284	13
2 x 373/4	20	42	221/2	231/2	241/4	175	2120	12
2 1/2 x 401/8	22	30	257/8	267/8	275/8	175	1724	10
3 x 451/8	24	29	285/8	297/8	307/8	175	1564	9
4 x 533/8	26	28	323/8	335/8	345/8	175	1160	7

CSAVCPS DIMENSIONS AND PRESSURE RATINGS (Metric Units)

±102mm ALL DIRECTIONAL SEISMIC MOVEMENT

Pipe* Size & End to End† (mm)	Live Length (mm)	Corrugations per meter	A (mm)	B (mm)	C (mm)	Rated Pressure @21°C (kg/cm²)	Min Burst Pressure (kg/cm²)	Safety Factor
15 x 549	356	289	381	400	413	12	302	25
20 x 562	381	197	400	419	432	12	222	18
25 x 594	406	164	432	451	464	12	220	18
32 x 730	432	154	467	486	498	12	186	15
40 x 772	483	144	524	543	556	12	160	13
50 x 959	508	138	572	597	616	12	149	12
65 x 1019	559	98	657	683	702	12	121	10
80 x 1146	610	95	727	759	784	12	109	9
100 x 1356	660	92	822	854	879	12	81	7

*Female end fits over copper tubing, e.g. 1/2 x 20 (15 x 500mm) fits over 1/2" (15mm) tubing.

†End to End Tolerances: All Sizes, ±1/4"(6mm)



MASON - MERCER

350 Rabro Drive, Hauppauge, NY 11788 • FAX 631/348-0279

MASON- 631/348-0282 • Email info@Mason-Ind.com • Website www.Mason-Ind.com

MERCER- 631/582-1524 • Email info@Mercer-Rubber.com • Website www.Mercer-Rubber.com



07/2010
SP1007